

Installation Guide

Drip Edge Installation Guide

Assembly Overview:

Drip Edge Installation Guide

This guide is provided to assist you in the installation process. Additional assistance is available by calling us at 888-321-9630. Thank you for choosing Drexel Metals.

Contents:

Assembly Overview	1
Step 1: Installing 22ga Galv. Cleat	2
Step 2: Installing Miters	2
Step 3: Installing End Caps/Terms	2
Step 4: Installing Straight Lengths	3
Step 5: Installing Roofing Membrane	3
Detail: Drip Edge	4

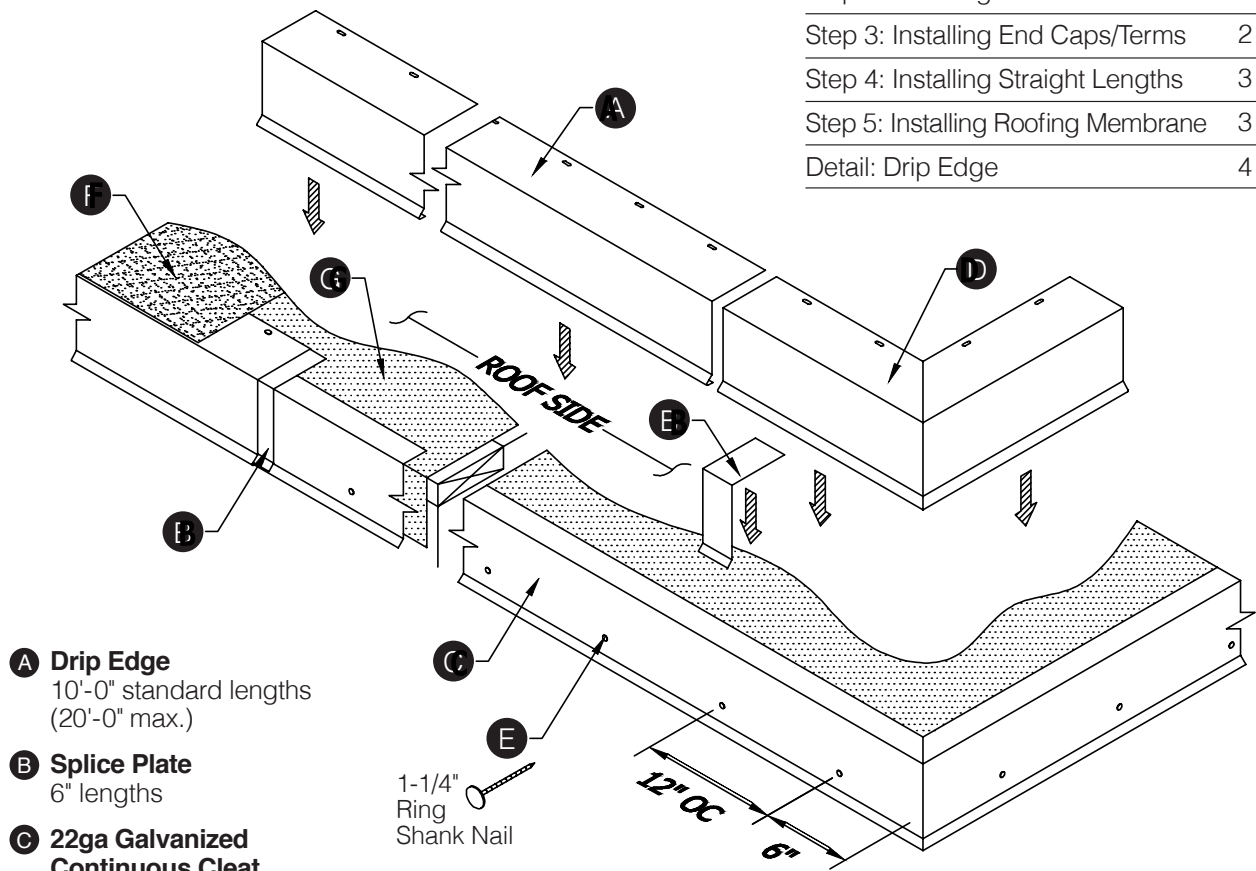

- A Drip Edge**
10'-0" standard lengths
(20'-0" max.)
- B Splice Plate**
6" lengths
- C 22ga Galvanized Continuous Cleat**
10'-0" lengths
- D Drip Edge Miter**
(Outside corner shown)
- E 1-1/4" S.S. Ring Shank Nail**
at 12" o.c. (6" from ends)
(Included and required)
- F 6" Cover Strip**
(By installer)
- G Approved Roofing Membrane**
(By installer)



Our Shop is Your Shop!

Installation: Drip Edge

Step 1: Installing 22ga Galvanized Cleat

- Place the top lip of the Cleat squarely on the top edge of the roofing membrane and treated wood nailing plate.
- Press Cleats securely in position and nail through the pre-punched holes with 1-1/4" S.S. Ring Shank Nails provided.
- For Miter application, fit into corner as required to maintain a continuous Cleat line.
- Nail at a minimum 6" in each direction from the corner or closer at special conditions.

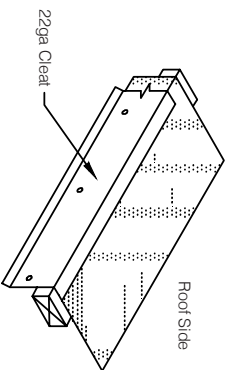

Step 2: Installing Drip Edge Miters

- Locate the Miters and Splice Plates for the appropriate corners.
- Place a Splice Plate under each end of the Miter sections.
- Install the Miter by hooking the Drip Edge Miter onto the kickout of the Cleat, and rotate back onto the roof.
- Fasten with 1-1/4" S.S. Ring Shank Nails provided into each pre-punched hole.

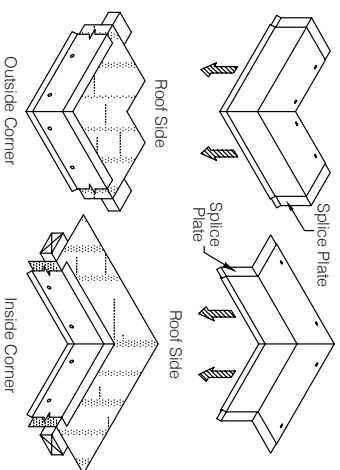

Step 3: Installing Drip Edge End Caps/Terms

- Install the Drip Edge End Caps and End Terms by hooking the drip of the Drip Edge End Cap or Term onto the kickout of the Cleat and rotate onto the roof.
- Fasten with 1-1/4" S.S. Ring Shank Nails provided, in each pre-punched hole.

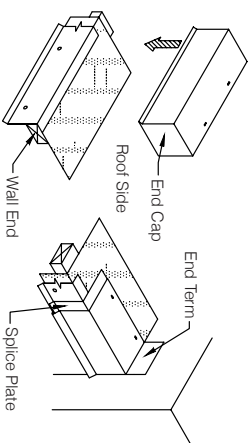

Installation: Drip Edge

Step 4: Installing Drip Edge Straight Lengths

- Place a Splice Plate in the opposite end of the installed Miter or End Cap.
- Install the Drip Edge by hooking the drip onto the kickout of the Cleat and rotate back onto the roof.
- Fasten with 1-1/4" S.S. Ring Shank Nails provided, in each pre-punched hole. **Allow 1/4" Gap between Drip Edge lengths for thermal expansion.**

- Consider lengths of all straight pieces prior to cutting to avoid creating relatively short sections adjacent to one another.

Note: There should be a Splice Plate at every joint.

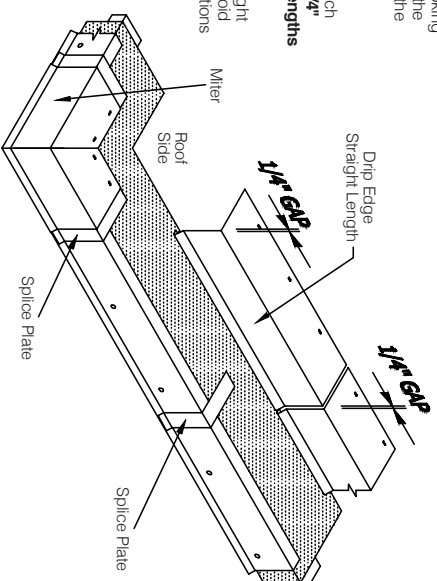

Step 5: Installing Approved Roofing Membrane

- Install 6" Cover Strip per roofing manufacturer's instructions

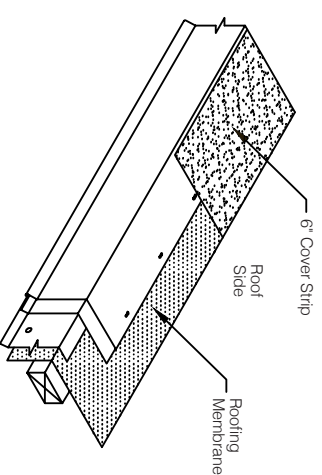

Drip Edge

Detail: Drip Edge

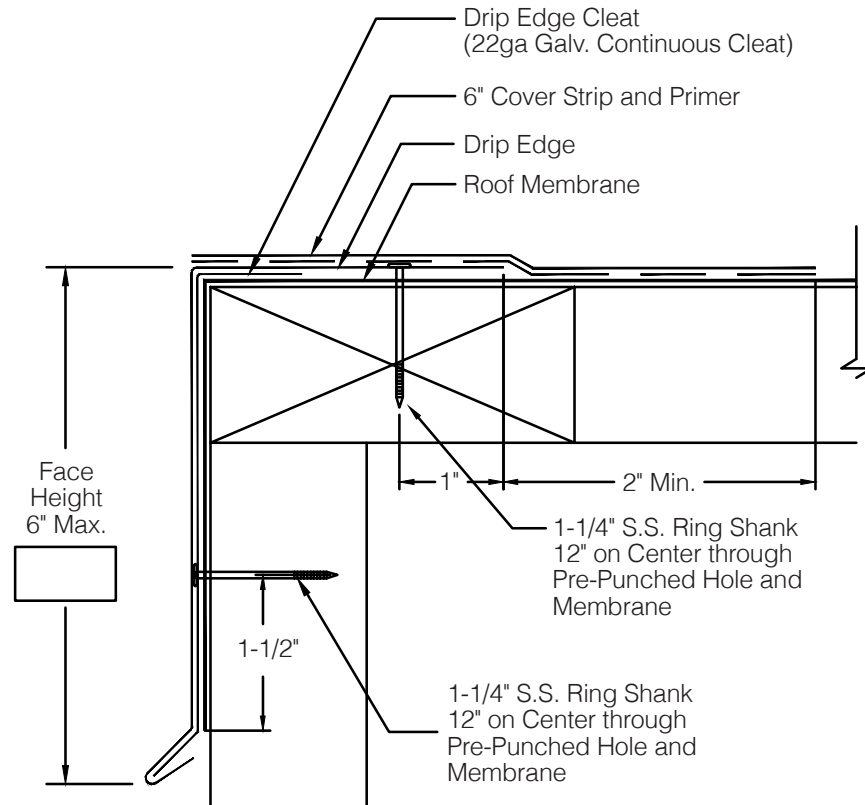

Notes:

1. Isolate all metal parts from ACQ treated wood or other galvanically incompatible material with appropriate membrane material.
2. Appliance attachments, such as lightning rods, signs, or antennae that penetrate the water seal, induce a galvanic reaction, or otherwise compromise the effectiveness of the roof edge system, shall be eliminated or isolated to prevent problems per section 8.0 if ANSI/SPRI ES-1. Appliances should also be isolated from, or not attached to, the roof edge system. Consult the lightning protection system manufacturer for specific attachment instructions.



Our Shop is Your Shop!

41 North Lawn Ave / Elmsford, NY 10523

Ph. 914-347-8157

Fax 914-347-8191

web: www.tsmny.com

email: sales@tsmny.com