

Installation Guide



41 North Lawn Ave / Elmsford, NY
10523 Ph. 914-347-8157
Fax 914-347-8191
web: www.tsmny.com
email: sales@tsmny.com

Our Shop is Your Shop!

Assembly Overview:

Snap Gravel Stop LT Installation Guide

This guide is provided to assist you in the installation process. Additional assistance is available by calling us. Thank you for choosing TriState Metals!

Contents:

Assembly Overview	1
Step 1: Installing 22ga Galv. Cleat	2
Step 2: Installing Cured Cover Strip	2
Step 3: Installing Miters	2
Step 4: Installing End Caps/Terms	3
Step 5: Installing Straight Lengths	3
Detail: Snap Gravel Stop LT	4

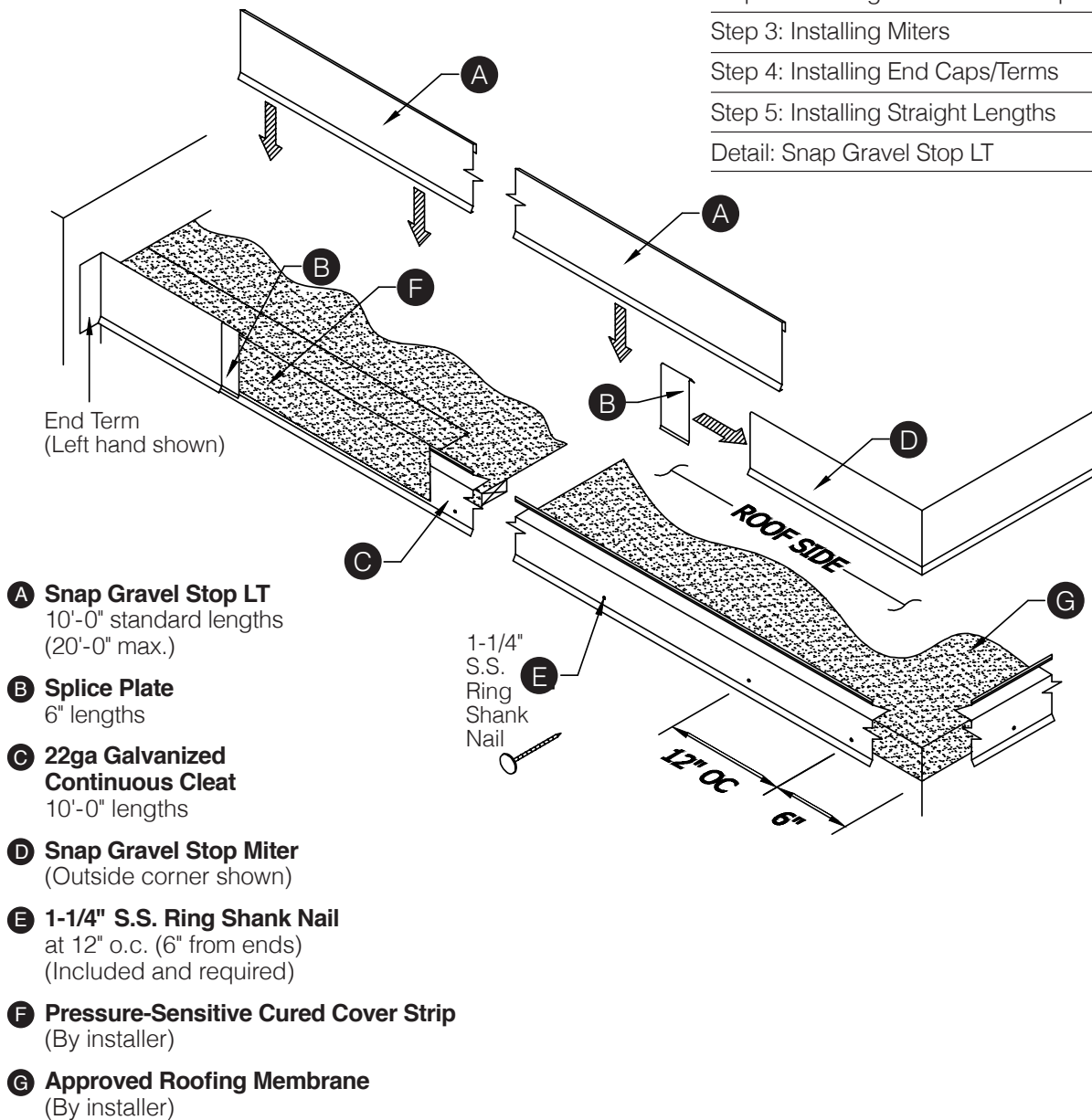

Installation: Snap Gravel Stop LT

Installation Guide



Our Shop is Your Shop! email: sales@tsmny.com

41 North Lawn Ave / Elmsford, NY

10523 Ph. 914-347-8157

Fax 914-347-8191

Web: www.tsmny.com

Step 1: Installing 22ga Galvanized Cleat

- Place the face of the Cleat squarely on the edge of the roof membrane over the treated wood nailing plate.
- Press securely in position and nail through the pre-punched face holes with 1-1/4" S.S. Ring Shank Nails provided.
- For Miter application, miter cut into corner as required to maintain a continuous Cleat line.
- Then nail at a minimum 6" in each direction from the corner or closer at special conditions.

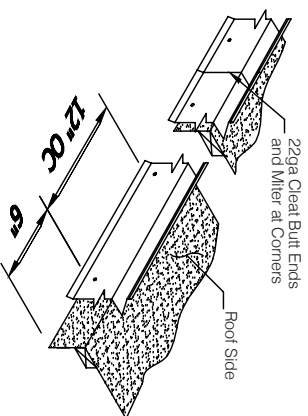

Step 2: Installing Pressure-Sensitive Cured Cover Strip

- Apply Pressure-Sensitive Cured Cover Strip to cant of 22ga Cleat and down Cleat face per roofing membrane manufacturer's installation details.

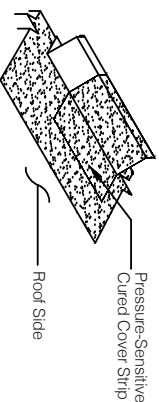

Step 3: Installing Snap Gravel Stop Miters

- Locate the Miters and Splice Plates for appropriate corners.
- Place a Splice Plate under each end of the Miter sections.
- Install the Miter by hooking the Snap Gravel Stop Miter onto the kickout of the Cleat, and rotate back onto the Cleat.

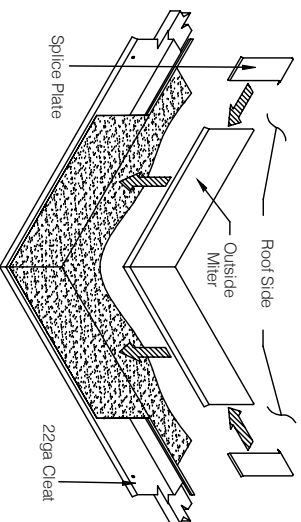

Step 4: Installing Snap Gravel Stop End Caps/Terms

- Install the Gravel Stop End Caps and End Terms by hooking the drip of the Snap Gravel Stop End or Term onto the kickout of the Cleat, and rotating back onto the Cleat.

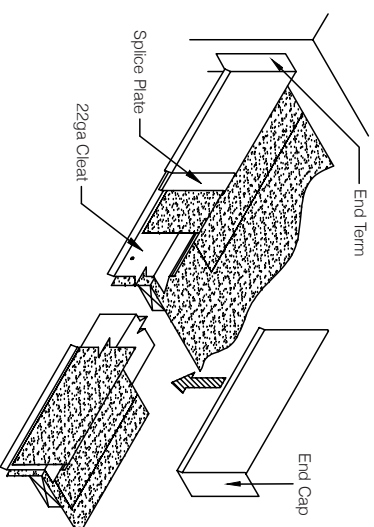

Step 5: Installing Snap Gravel Stop Straight Lengths

- Place a Splice Plate in the opposite end of the installed Miter or End Cap.
 - Install Snap Gravel Stop by hooking the Gravel Stop onto the kickout of the Cleat, and rotating back onto the Cleat. **Allow 1/4" gap between Snap Gravel Stop lengths for thermal expansion.**
 - Consider lengths of all straight pieces prior to cutting to avoid creating relatively short sections adjacent to one another.
- Note: There should be a Splice Plate at every joint.

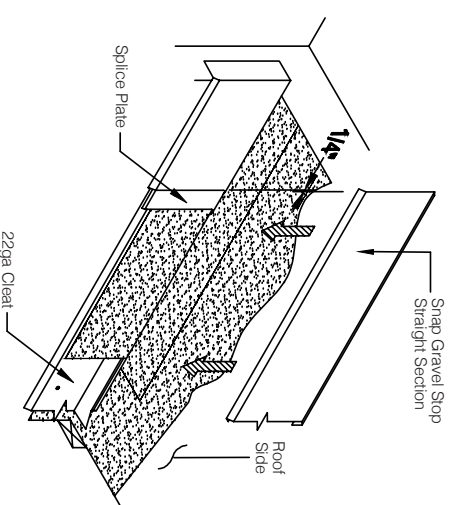

Snap Gravel Stop LT

Detail: Snap Gravel Stop LT – performance series

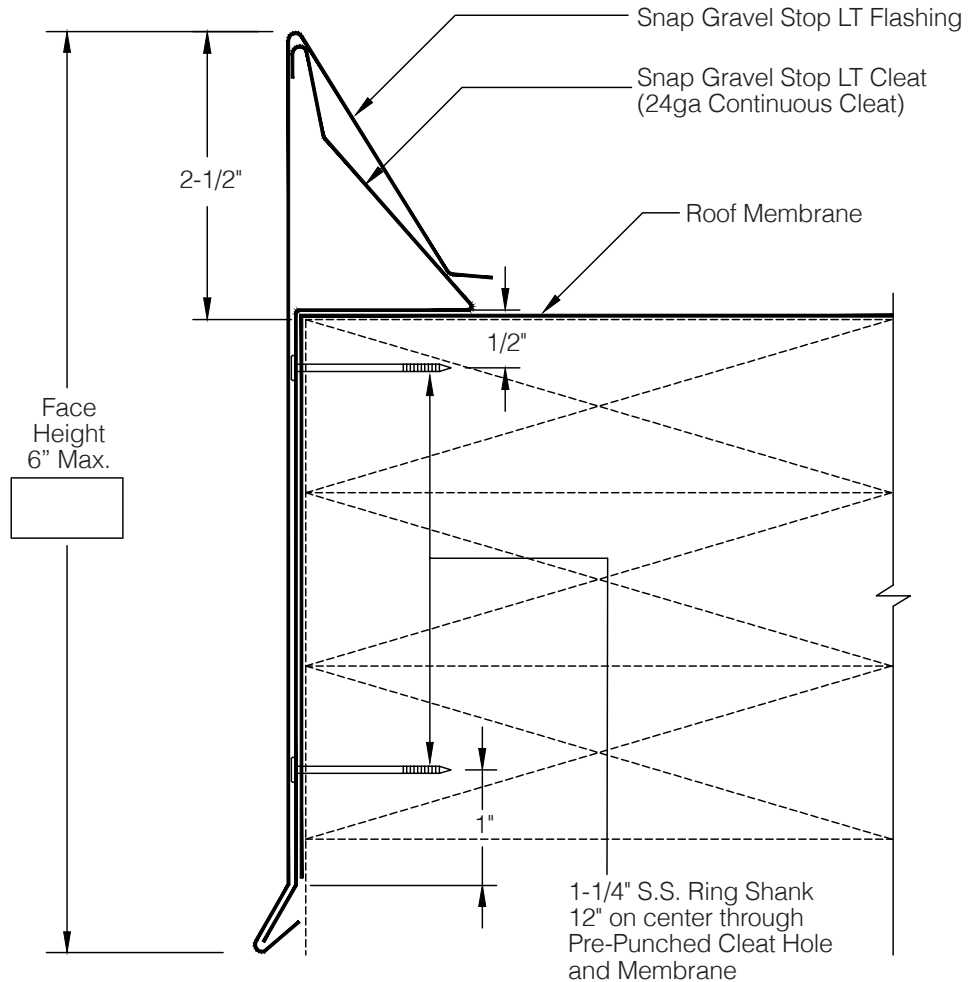

Notes:

1. Isolate all metal parts from ACQ treated wood or other galvanically incompatible material with appropriate membrane material.
2. Appliance attachments, such as lightning rods, signs, or antennae that penetrate the water seal, induce a galvanic reaction, or otherwise compromise the effectiveness of the roof edge system, shall be eliminated or isolated to prevent problems per section 8.0 if ANSI/SPRI ES-1. Appliances should also be isolated from, or not attached to, the roof edge system. Consult the lightning protection system manufacturer for specific attachment instructions.



41 North Lawn Ave / Elmsford, NY

10523 Ph. 914-347-8157

Fax 914-347-8191

web: www.tsmny.com

email: sales@tsmny.com

Our Shop is Your Shop!