

# Fascia EC

ANSI/SPRI ES-1 CERTIFIED:  
 .032" AL = 430 psf, .050" AL = 160 psf  
 24GA Steel = 300 psf, 22GA Steel = 160 psf

Cleat Part Number	"F" Dim.	"X" Dim.	Nailers Covered
<input type="checkbox"/> EFC4	4"	3-1/4"	1
<input type="checkbox"/> EFC5.5	5-1/2"	4-3/4"	2
<input type="checkbox"/> EFC7	7"	6-1/4"	3
<input type="checkbox"/> EFC8.5	8-1/2"	7-3/4"	4
<input type="checkbox"/> EFC10	10"	9-1/4"	5
<input type="checkbox"/> EFC11.5	11-1/2"	10-3/4"	6

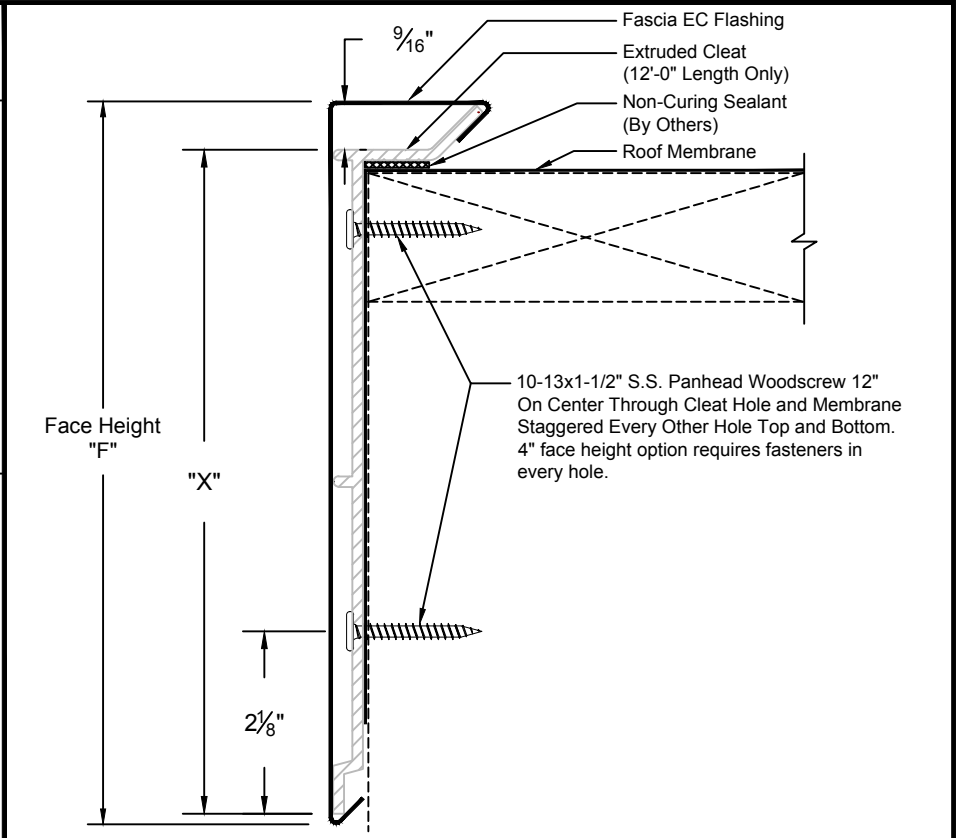

- Maximum tested Face Height "F" for .032"AL and 24GA Steel is 8-1/2".
- Face Height "F" of 10" and 11-1/2" require .050"AL or 22GA Steel.

- Continuous Cleat and Fasteners provided.
- Concealed Splice Plates provided.
- Splice Plate Sealant available for extra charge.

## PRINT APPROVAL:

Architect and/or Contractor shall verify all dimensions, sizes, and quantities, All products to be installed in strict accordance with TSM's printed instructions.

Approved By: \_\_\_\_\_  
 Date: \_\_\_\_\_

## QUANTITIES:

- Lineal Feet (10'-0" Lengths): \_\_\_\_\_
- Outside Miters\*: \_\_\_\_\_  Optional Welded (Surcharge Applies)
- Inside Miters\*: \_\_\_\_\_  Optional Welded (Surcharge Applies)
- Right End Caps\*: \_\_\_\_\_  Optional Welded (Surcharge Applies)
- Left End Caps\*: \_\_\_\_\_  Optional Welded (Surcharge Applies)
- Splice Plate Tape Sealant:  Optional Sealant (Surcharge Applies)

\* Standard riveted

PROJECT:

ARCHITECT:

ROOFING CONTRACTOR:

REPRESENTATIVE:

## MATERIAL:

- .032" AL  .040" AL  
 .050" AL  24GA  
 22GA  Other: \_\_\_\_\_

Finish: \_\_\_\_\_

Color: \_\_\_\_\_

Effective Date: 1-1-19

Drawn By: J.S.

Approved By: B.P.



41 North Lawn Ave / Elmsford, NY 10523  
 Ph. 914-347-8157  
 Fax 914-347-8191  
 web: www.tsmny.com  
 email: [sales@tsmny.com](mailto:sales@tsmny.com)

*Our Shop is Your Shop!*